

Model EL



*Shown with options

**OLE HICKORY
PITS**

WOOD BURNING BARBECUE PITS

Revolving Racks: (15) 12" x 36", Cooking Surface: 45 Sq. Ft.

1-800-223-9667

333 North Main Street ~ Cape Girardeau, MO

Email: main@olehickorypits.com ~ Website: www.olehickorypits.com

MODEL EL

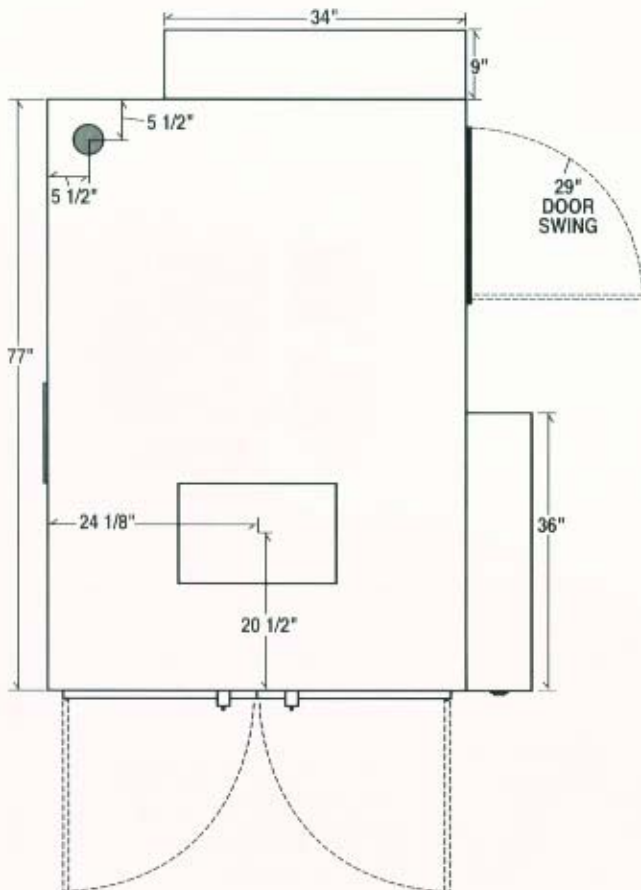
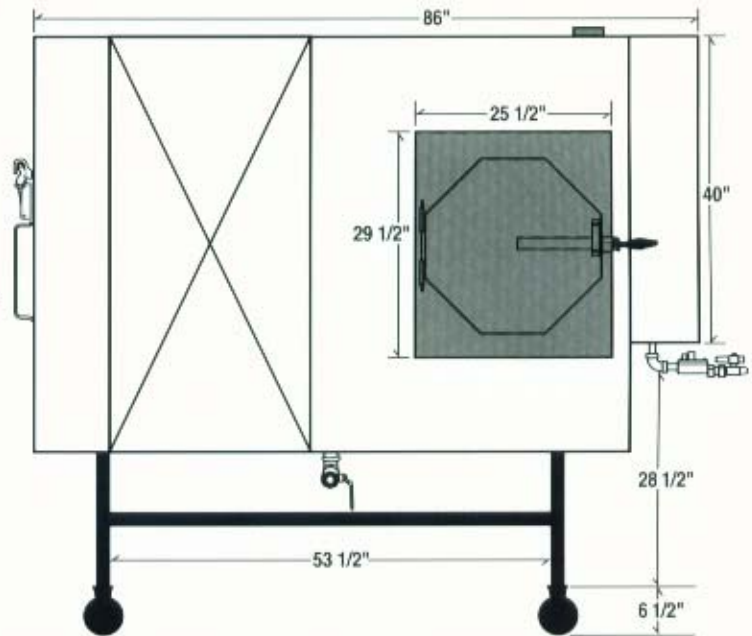
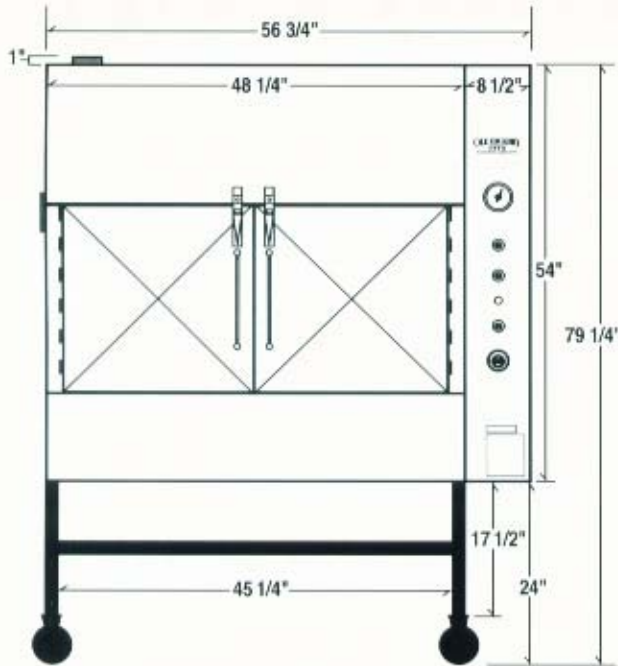

Construction: *Heavy Duty 12 Gauge Steel Interior (100% welded & inspected seams) Tubular Steel Frame, 22 gauge stainless steel exterior, Mineral Wool Insulation- rated 1200 degrees F. (contains no asbestos or Fiberglass)*

Electrical: 110 Volts, 60HZ, Single Phase, 15 Amp - AVOID NON-GROUNDED EXTENSION CORDS.

Gas Burner: 65,000 BTU Burner with Electronic ignition, available in L.P. or Natural Gas.

Firebox: Two (2) regular fireplace size log will last for up to 6 hours of cooking. Air over firebox circulation.

Temperature Range: Thermostat control range 100 degrees F. to 325 degrees F.

Upper Limit Control Switch: Extra Safety Feature.

Dial Thermometer: 2 1/2" Diameter.

Heavy Duty Foot Switch: Rotisserie Advance.

Casters: Four (4) Heavy Duty, ETL Approved.

Convection System: One (1) 1/4 HP motor with 10" fan blade provides a mix of both heat and smoke for product consistency.

Flue: 4" diameter.

Grease Drain: 2" Pipe with 2" Ball Valve.

Weight: 1860 lbs. uncrated.

Rotisserie: 15 Racks, 12" X 36", 45 Sq. Ft. Cooking Surface. Nickel-chrome (stainless available at extra cost) Removable for easy cleaning.

Rotisserie Drive: Heavy Duty 1/4 HP Motor - long lasting chain drive system utilizing gear reduction.

